

Führungsscheiben

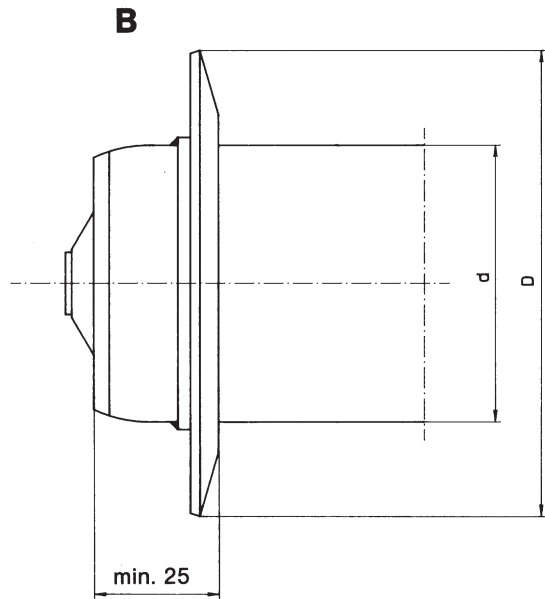
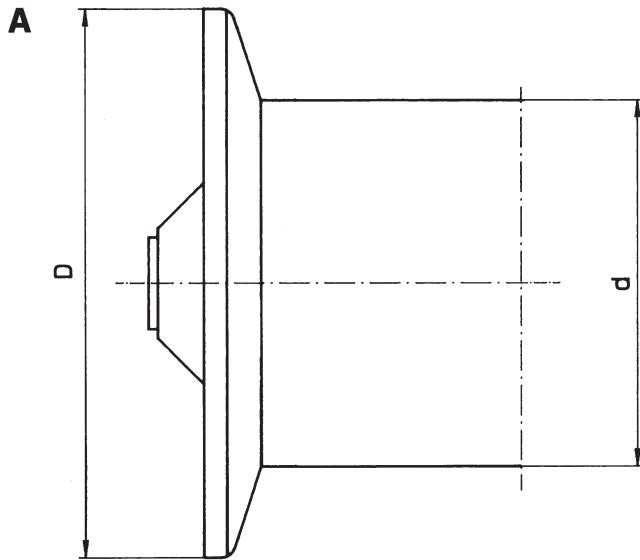
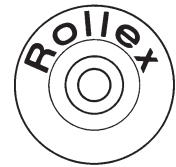

	d	D			
A	30	60			
	40	60			
	50	70			
B	50	70			
	60	95	110	120	
	63,5	130			
	80	130	135	140	150
	88,9	130	135	140	150
	108	160			

Sondermaß als Drehteil nach Wunsch

Stützringe

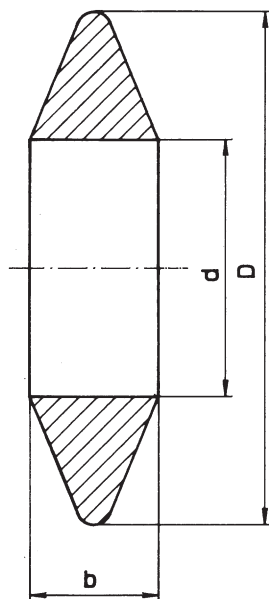

Rohr-Ø	D	d	b
63,5	108	60	25
63,5	133	60	30
88,9	133	85	30
88,9	159	85	30
108	159	104	30

weitere Abmessungen auf Anfrage

Pufferringe

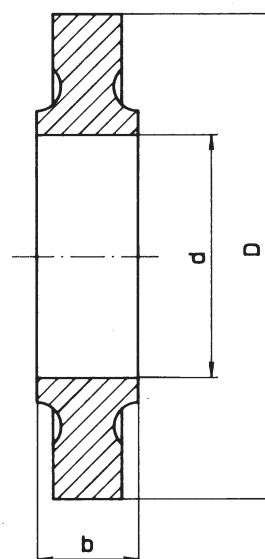

Rohr-Ø	D	d	b
50	89	48	30
63,5	89	60	25
63,5	108	60	30
88,9	133	86	35
88,9	159	86	35